

Baking Unit

SVC Series



■ Outlines

- SVC Series: Baking unit delivers vaporized gas supply through a mass flow controller within an incorporated tank

■ Functions

- Optimizing temperature control of the supply line to avoid liquefaction
- All-in-one design is compatible with wiring of various bubbling supply utilities
- Customization depends on physical properties of precursor, flow rate and operating environment
- Clean design makes maintenance convenient
- Various alarm functions equipped
- Safe and stable design optimal for various precursors

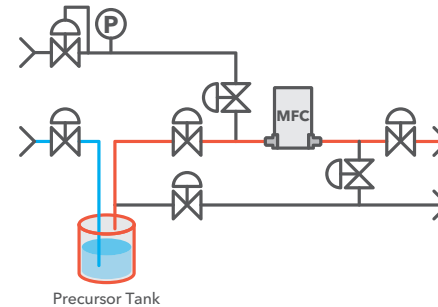

LINTEC

Home Page
<http://www.lintec-mfc.co.jp>